

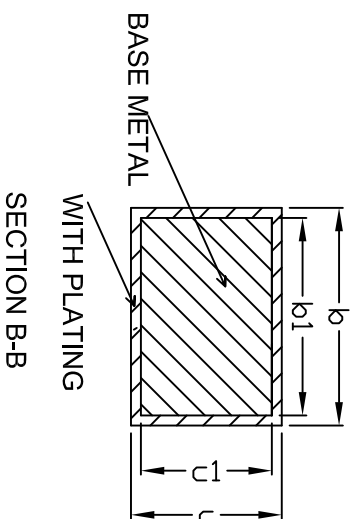

SOP14 PACKAGE OUTLINE DIMENSIONS

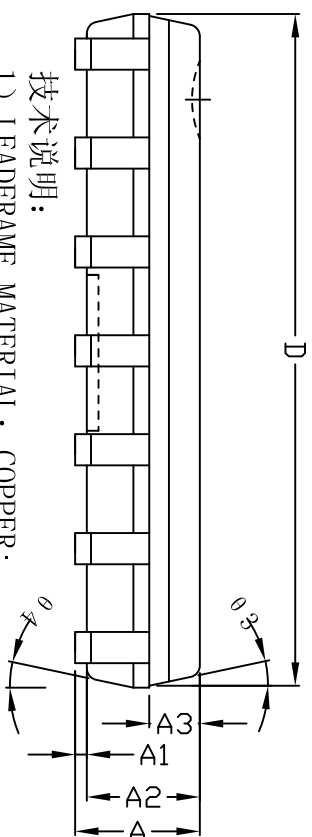
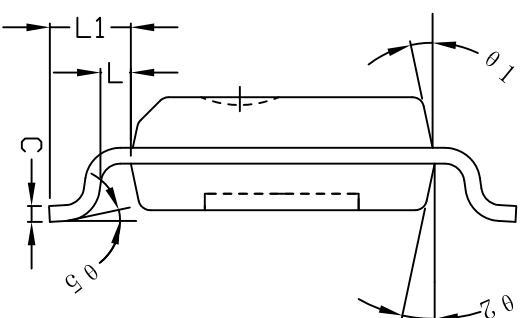
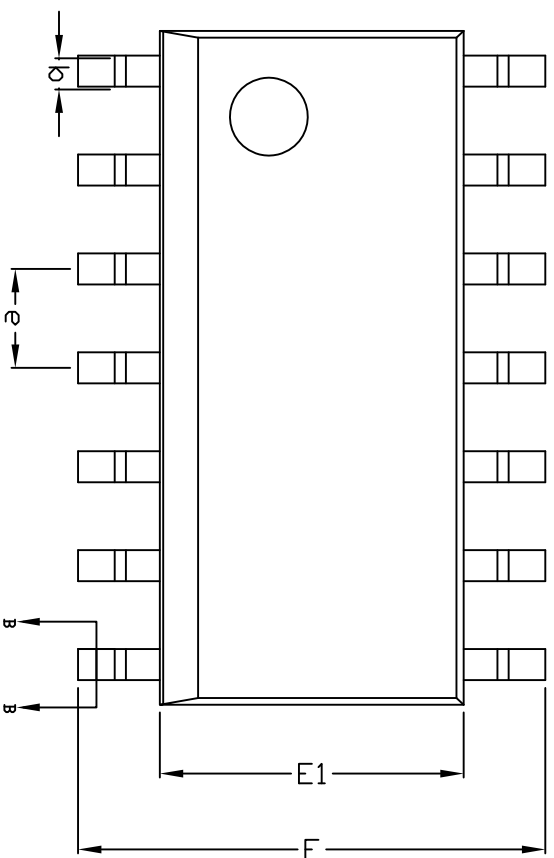

| SYMBOL | MILLIMETER |      |      |
|--------|------------|------|------|
|        | MIN        | NDM  | MAX  |
| A      | --         | --   | 1.70 |
| A1     | 0.10       | 0.15 | 0.21 |
| A2     | 1.40       | 1.45 | 1.50 |
| A3     | 0.60       | 0.65 | 0.70 |
| b      | 0.39       | --   | 0.46 |
| b1     | 0.38       | 0.41 | 0.44 |
| c      | 0.20       | --   | 0.24 |
| c1     | 0.19       | 0.20 | 0.21 |
| D      | 8.45       | 8.60 | 8.25 |
| E      | 5.80       | 6.00 | 6.20 |
| E1     | 3.75       | 3.85 | 4.00 |
| e      | 1.27(BSC)  |      |      |
| L      | 0.50       | 0.60 | 0.70 |
| L1     | 1.10REF    |      |      |
| θ1     | 8°         | ~    | 15°  |
| θ2     | 8°         | ~    | 15°  |
| θ3     | 8°         | ~    | 15°  |
| θ4     | 8°         | ~    | 15°  |
| θ5     | 0°         | ~    | 6°   |

技术说明:

1) LEADFRAME MATERIAL: COPPER;

引线框架材料: 铜;

2) LEADFRAME THICKNESS: 0.203mm;

引线框架厚度: 0.203mm;

3) BOTH PACKAGE LENGTH AND WIDTH DO NOT INCLUDE MOLD FLASH;

塑封体长度及宽度尺寸不包括塑封溢胶;

4) REFERENCE: JEDEC MS-013, MS-012。

参考标准: JEDEC MS-013, MS-012。